



A PRODUCT SHEET OF NEPTUNE TECHNOLOGY GROUP

R900[®] Wall or Pit Meter Interface Unit (MIU)



Build Onto Your Existing Technology Investment

As part of Neptune's R900[®] System, the R900[®] meter interface unit (MIU) was designed for flexibility. Like its fellow system components, the R900 MIU works seamlessly with prior generations of reading equipment. At the same time, it allows your utility to incorporate innovations as your needs grow. A single radio frequency unit that can transmit meter reading data using multiple reading methods – mobile or fixed network – the R900 MIU never has to be reprogrammed. That makes migrating to new technologies simple whenever your utility is ready to implement them. When it's time to add new features or functionality, you can do it at your own pace, confident of continual system support without concern for stranded assets.

Eliminate Infrastructure Costs and Ongoing Network Maintenance

As part of the Neptune[®] Managed Services platform, the R900 was designed to eliminate the costs, frustrations, and maintenance of deploying your own AMI network infrastructure. Leveraging LoRa[®] Network-as-a-Service (NaaS) technology, your utility can now cover your service area with no operational burden, free to focus on water delivery and billing. Mobile and fixed network messages are interleaved and continuously transmitted, allowing your utility to maintain backup mobile reading capability of the same endpoints.

Reduce Complaints, Delinquencies, And Write-Offs

Neptune's R900 MIU greatly improves access to meter readings, while delivering detailed consumption profile information as well as alerts for leak or backflow, helping your utility more proactively identify and resolve customers' questions. This accurate, timely data can be used to head off high bill complaints, reduce delinquent payments, and eliminate write-offs.

Because detailed data logging information from the last 96 days is always available, just waiting to be transmitted by the R900 MIU when needed, personnel can take care of a customer's issue then and there, in a single site visit. Not only can the data boost efficiency and customer service, but it will also help your utility make better-informed decisions going forward.

KEY BENEFITS

Facilitates Migration to AMI

- Eliminate the maintenance and burdens of deploying AMI network infrastructure with Network-as-a-Service using LoRaWAN[™] technology
- Interleaved mobile and fixed network messages facilitate migration without changing the "modes" in the MIU

Reduces Non-Revenue Water

- Provides leak history/diagnostics
- Enables proactive leak notification
- Provides hourly consumption data
- Improves meter reading accuracy
- Eliminates estimated reads

Identifies Potential Theft

- Tamper detection
- Reverse flow detection
- Identifies significant periods of zero consumption

Simplifies Installation Process

- Easy to install/no programming required
- Reduces labor cost

Technical Specifications

Electrical Specifications

- MIU power: Lithium battery with capacitor

Transmitter Specifications

- Two-way MIU
- Transmit Options (interleaved mobile and fixed network messages):
 - R900 mobile message
 - R900 fixed network message
 - LoRa fixed network message
- FCC verification: Part 15.247
 - Transmitter channels: 50 (R900 mobile and fixed network messages) and 64 (LoRa fixed network message); frequency-hopping, spread-spectrum
 - Channel frequency: 902 to 928 MHz
- Encoder register reading interval:
 - Every 15 minutes
- Data logging interval:
 - 96 days of hourly data

Environmental Conditions

- Operating temperature: -22°F to +149°F (-30°C to +65°C)
- Storage temperature: -40°F to +158°F (-40°C to +70°C)

- Operating humidity: 100% condensing

Antennas

- Wall MIU: standard internal antenna
- Pit MIU: standard through-the-lid antenna
 - 18" Coax
 - 6' Coax
 - 20' Coax

Encoded Register Compatibility

- Neptune ARB® V, ProRead™, ProCoder™, and E-CODER®
- Sensus ECR II, ICE, iPerI, Electronic Register and OMNI
- Hersey/Mueller Translator
- Badger ADE and HR E|LCD
- Elster/AMCO InVision (Sensus protocol version)

Options

System Compatibility

- Handhelds with R900® Belt Clip Transceiver - mobile RF
- MRX920™ - mobile RF
- R900® Gateways - fixed network RF
- LoRa LPWA IoT Network

Dimensions

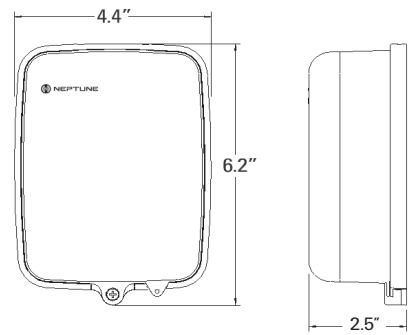

R900 Wall MIU

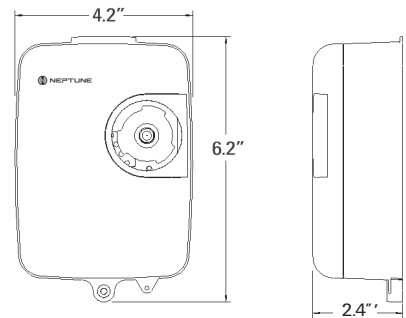

R900 Pit MIU

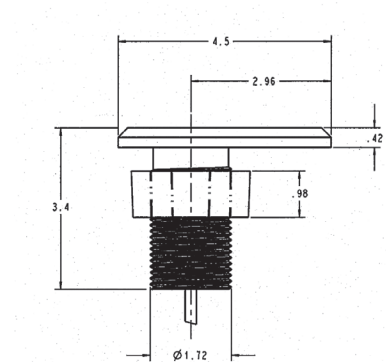

R900 Pit Antenna

 LoRa Alliance Certified™

Accu-Flo
1-800-921-2228
www.accuflo.com



#winyourday
neptunetg.com