



VEEDER-ROOT
INSTALLATION, OPERATION
AND SERVICE INSTRUCTIONS

Technical Manual
8-014
Issued: 12/95
Supersedes : 5/93

SERIES 7886 HIGH-CAPACITY & SERIES 7887 METER REGISTERS

Manual No. 251325 (REV. B)

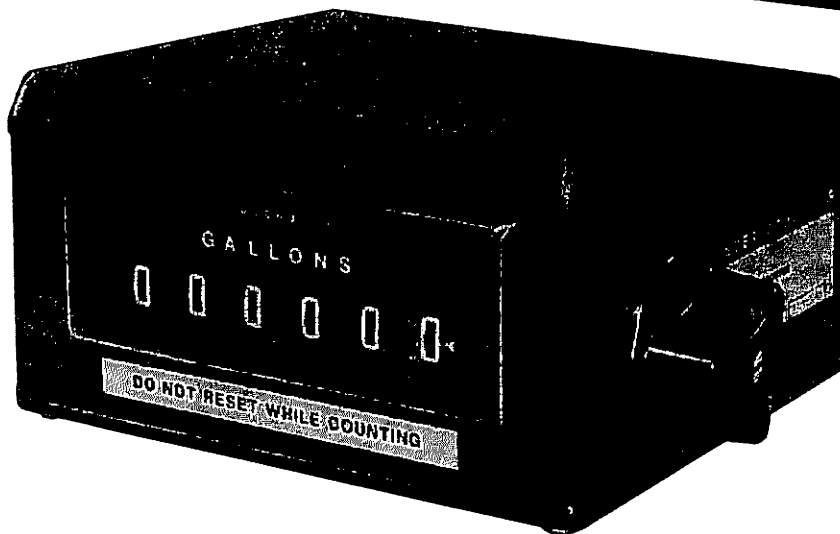
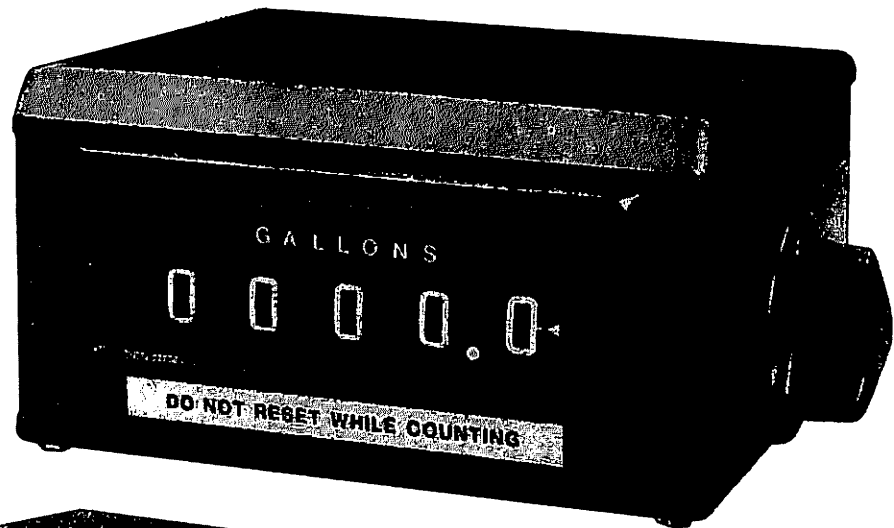

Accu-Flow 
Meter Service Ltd.

TABLE OF CONTENTS

SECTION 1. INTRODUCTION

A. General 1

SECTION 2. SERIES 7887 DESCRIPTION

A. General 1
B. Specifications 2

SECTION 3. SERIES 7886 DESCRIPTION

A. General 3
B. Specifications 3

SECTION 4. PERIODIC INSPECTION

A. General 5
B. Disassembly Prior to Cleaning 5
C. Cleaning 5
D. Inspection 5
E. Lubrication 5
F. Troubleshooting 7

SECTION 5. DISASSEMBLY AND ASSEMBLY

A. General 8
B. Removal of Major Groups 8
C. Individual Parts Replacement10
D. Installation of Major Groups10
E. Final Checks and Adjustments15
F. Operational Check16

SECTION 6. DAMAGE CLAIMS AND WARRANTY

A. Damage Claims16
B. Return Shipping16
C. Warranty and Conditions16

SECTION 1. INTRODUCTION

A. GENERAL. These instructions are for servicing the Series 7886 High-Capacity and Series 7887 Meter Registers designed and manufactured by the Veeder-Root Company, 6th Avenue at Burns Crossing, P.O. Box 1673, Altoona, PA 16603. Phone: (814) 695-4476.

When a vertical bar | appears adjacent to text or illustrations, information has been added or changed at the last issue date.

Note: Consult Veeder-Root on any unusual application, installation or possible modification of this basic design.

Every Meter Register is thoroughly tested at the Veeder-Root factory and by the meter manufacturer when installed on the meter. However, like any precision mechanism, it requires periodic care to ensure maximum service. This manual is for use in areas where factory rebuilding facilities and adequate exchange stocks are not readily accessible.

Where manufacturer's replacement stocks are available, it is important that no attempt be made to repair any meter register defective within the terms of the warranty as by doing so, the warranty is void and the user is deprived of the protection provided by the warranty. It is recommended that, when possible, meter registers be replaced and the defective unit returned to the meter manufacturer.

Note: See Section 6 for complete Damage Claims and Warranty.

IMPORTANT!

The instructions, photographs and drawings in Sections 4 and 5 are based on the Series 7887 Meter Register. With the exception of an additional counting wheel, the Series 7886 High-Capacity Meter Register is physically similar and the same procedures should be followed.

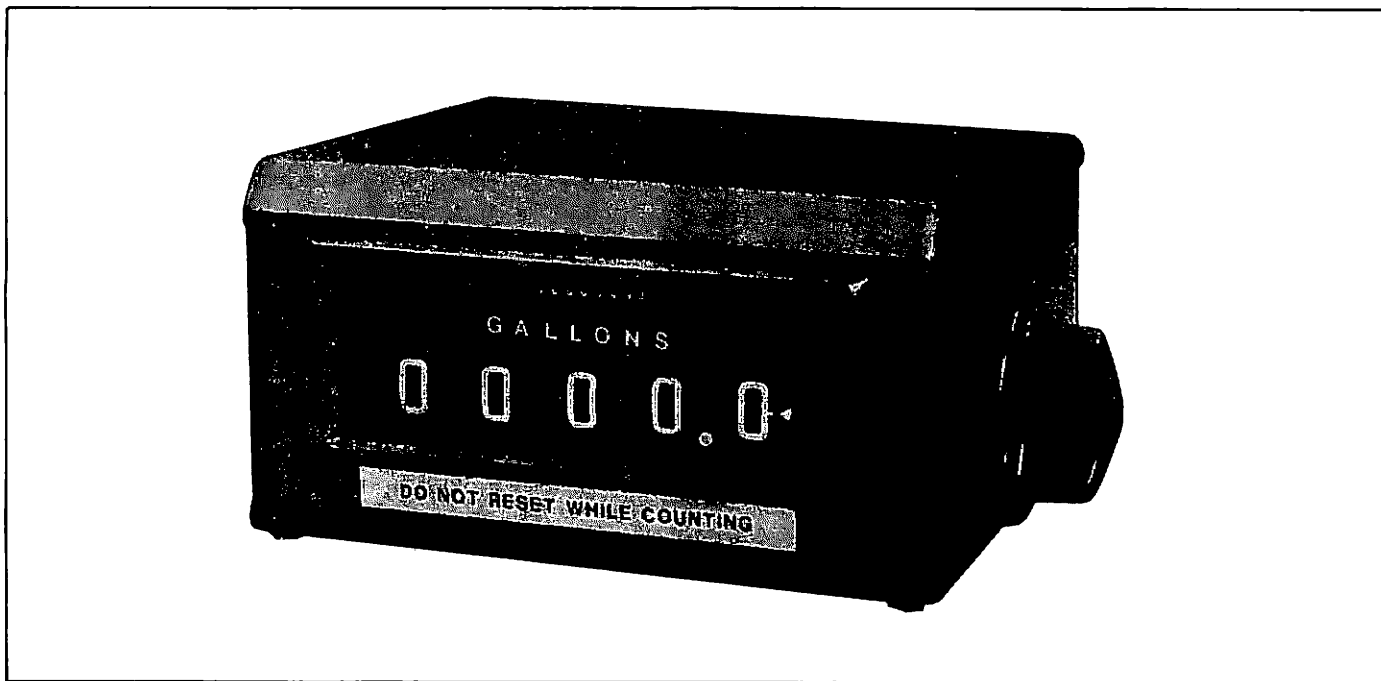

Figure 1. External View of Series 7887 Meter Register.

SECTION 2. SERIES 7887 DESCRIPTION

A. GENERAL.

1. Physical. The Series 7887 Meter Register, Figure 1, displays a running account, final total and accumulated total of the quantity of liquid product delivery. Contained in a 4" x 10" diecast enclosure, individual delivery data is displayed on five 3/4" high figures while totalizer information is recorded on eight 1/8" high figures. Reset of the Meter Register is accomplished through a reset knob on the right-hand side of the unit.
2. Operational. The Meter Register is operated by a drive shaft connected to a group of gears on the gear plate which converts the drive revolutions to the appropriate ratio. The output bevel gear of the group drives a bevel gear, Figure 5, which is connected to the drive shaft and clutch assembly. In rotating, this shaft drives a gear on the

clutch assembly which in turn drives a gear on the right (unit) wheel assembly. Revolutions are then accumulated on the wheels. In addition, this rotating shaft drives the bracket group connected to the accumulative totalizer shaft, thus both displays are driven from the same source, assuring accurate recording of information. During the reset operation, the clutch is disconnected from the drive shaft, a shutter moves into place covering the display wheels and reset fingers engage heart-shaped cams on the individual wheels to move them back to a zero position. In addition, a set of anti-topping fingers engages the wheels to prevent jamming. At the completion of reset, the display wheels will read all zeros, and the shutter will rise to the normal operating position. The clutch will engage the drive shaft to transfer the information from the next delivery. The totalizer wheels will be unaffected by this reset operation, thus displaying an accurate measure of the accumulated totals of many deliveries.

B. SPECIFICATIONS.

Specifications listed are standard unless otherwise noted. Optional features are available at additional cost.

Speed: 250 rpm.

Torque: Average running torque at room temperature with 1:1 input: 4 oz-in. During display wheel transfer from all 9's to all 0's, the instantaneous peak torque may reach 40 oz-in.

Operating Temperature Range: -40° to +71°C (-40° to +160°F).

Number of Figures: Meter Register: 5. Accumulative Totalizer: 8

Size of Figures: Meter Register: 0.750" high x 0.400" wide (19.05 x 10.16 mm). Totalizer: 0.125" high x 0.078" wide (3.175 x 1.98 mm).

Color of Figures: White on black, except right-hand totalizer wheel which is black on white when recording tenths of units, and white on black when recording whole units.

Style of Figures: Veeder-Root/Cornell for optimum readability.

Character Configuration: 0 to 9 (options available).

Reset: Single handle on register. Designed for one-handed operation.

Mounting: Eight 1/4 x 28 tapped holes with steel inserts on a 6.625" (168.28 mm) diameter. Special adaptors are available for nearly all meters.

Construction: Cover: cast aluminum. Case and sub frame: cast Zamak. Wheels, pinions, and clutch: acetal resin.

Gearing: 1:1 is standard. 1:1 through 42:1 are available.

Lubrication: Periodic.

OPTIONS

Nonreset Pulser: Meter Register with Series 1871 or 7671 Pulse Transmitter.

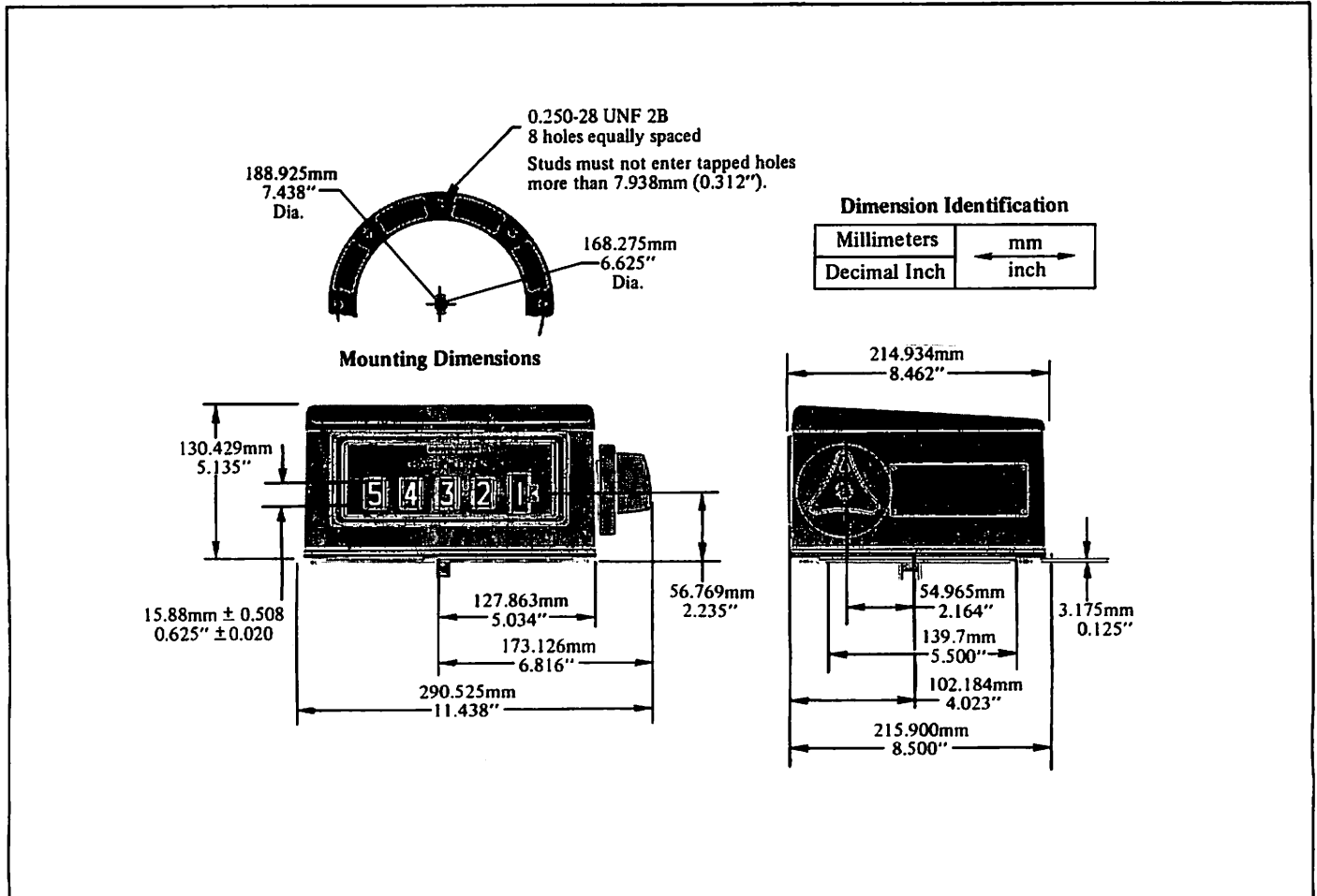

Figure 2. Mounting Dimensions — Series 7887 Meter Register.

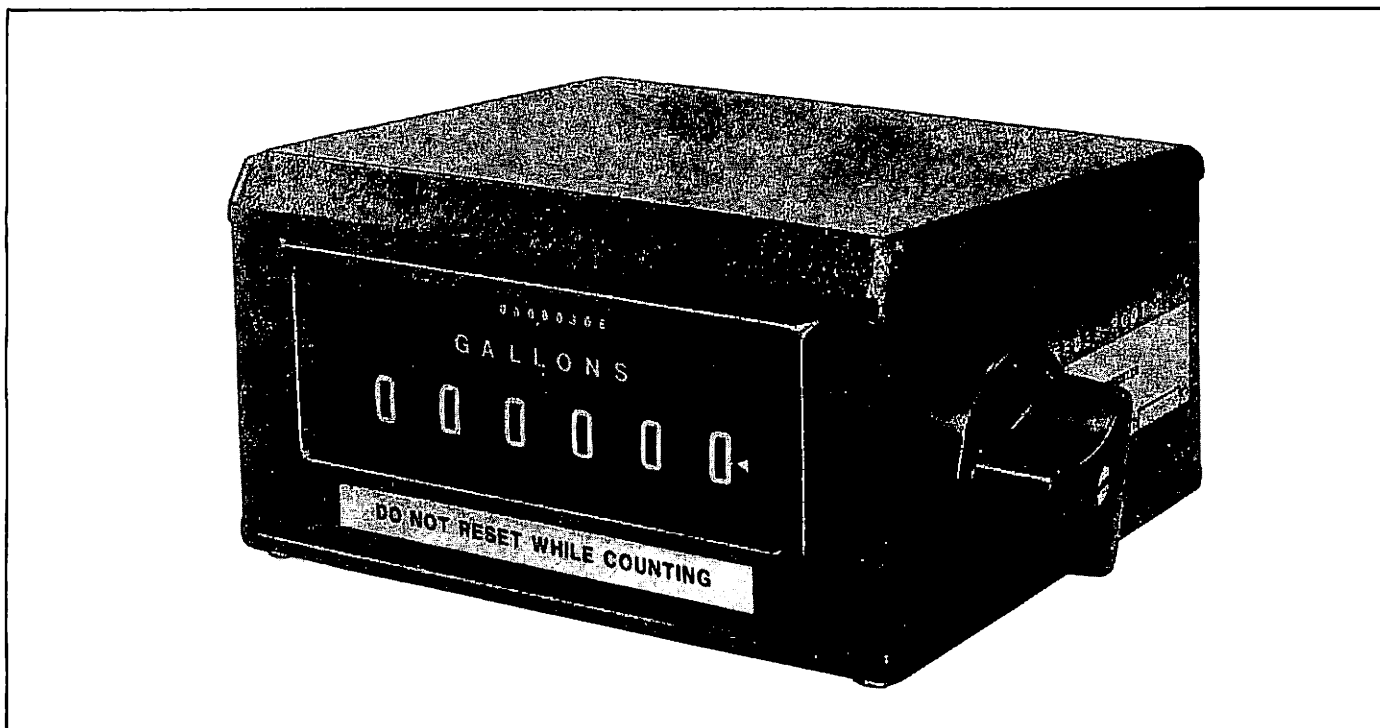

Figure 3. External View of Series 7886 High-Capacity Meter Register.

SECTION 3. SERIES 7886 DESCRIPTION

A. GENERAL.

1. Physical. The Series 7886 High-Capacity Meter Register, Figure 3, displays a running account, final total and accumulated total of the quantity of liquid product delivery. Contained in a 4" x 10" diecast enclosure, individual delivery data is displayed on six 5/8" high figures while totalizer information is recorded on eight 1/8" high figures. Reset of the Meter Register is accomplished through a reset knob on the right-hand side of the unit.
2. Operational. The Meter Register is operated by a drive shaft connected to a group of gears on the gear plate which converts the drive revolutions to the appropriate ratio. The output bevel gear of the group drives a bevel gear, Figure 5, which is connected to the drive shaft and clutch assembly. In rotating, this shaft drives a gear on the clutch assembly which in turn drives a gear on the right (unit) wheel assembly. Revolutions are then accumulated on the wheels. In addition, this rotating shaft also drives the bracket group connected to the accumulative totalizer shaft, thus both displays are driven from the same source, assuring accurate recording of information. During the reset operation, the clutch is disconnected from the drive shaft, a shutter moves into place covering the display wheels and reset fingers engage heart-shaped cams on the individual wheels to move them back to a zero position. In addition, a set of anti-topping fingers engages the wheels to prevent jamming. At the completion of reset, the display wheels will read all zeros, and the shutter will rise to the normal operating position. The clutch will engage the drive shaft to transfer the information from the next delivery. The totalizer wheels will be unaffected by this reset operation, thus displaying an accurate measure of the accumulated totals of many deliveries.

B. SPECIFICATIONS.

Specifications listed are standard unless otherwise noted. Optional features are available at additional cost.

Speed: 250 rpm.

Torque: Average running torque at room temperature with 1:1 input: 4 oz-in. During display wheel transfer from all 9's to all 0's, the instantaneous peak torque may reach 40 oz-in.

Operating Temperature Range: -40° to +71°C (-40° to +160°F).

Number of Figures: Meter Register: 6. Accumulative Totalizer: 8

Size of Figures: Meter Register: 0.625" high x 0.300" wide (15.87 x 7.62 mm). Totalizer: 0.125" high x 0.078" wide (3.175 x 1.98 mm).

Color of Figures: White on black, except right-hand totalizer wheel which is black on white when recording tenths of units, and white on black when recording whole units.

Style of Figures: Veeder-Root/Cornell for optimum readability.

Character Configuration: 0 to 9 (options available).

Reset: Single handle on register. Designed for one-handed operation.

Mounting: Eight 1/4 x 28 tapped holes with steel inserts on a 6.625" (168.28 mm) diameter. Special adaptors are available for nearly all meters.

Construction: Cover: cast aluminum. Case and sub frame: cast Zamak. Wheels, pinions, and clutch: acetal resin.

Gearing: 1:1 is standard. 1:1 through 42:1 are available.

Lubrication: Periodic.

OPTIONS

Nonreset Pulsar: Meter Register with Series 1871 or 7671 Pulse Transmitter.

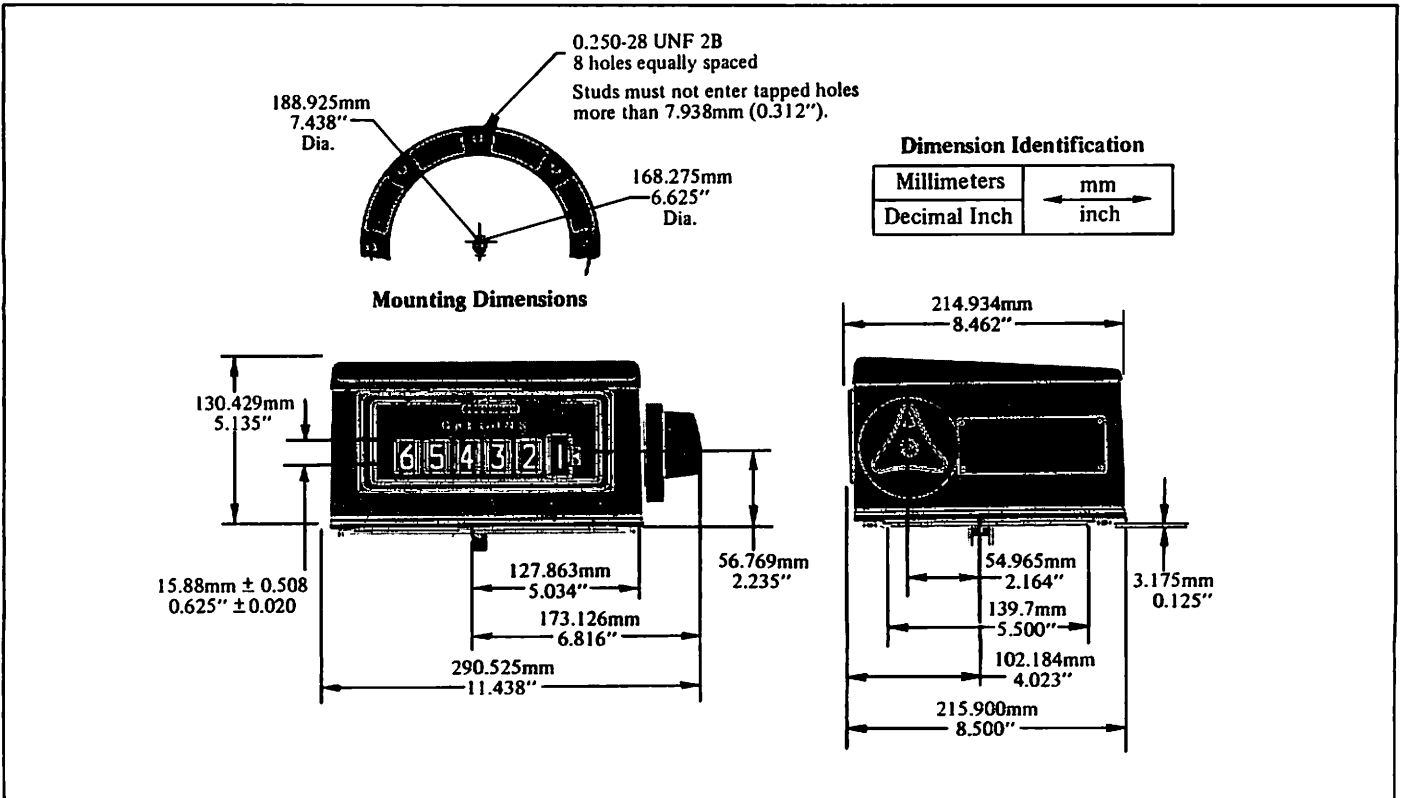

Figure 4. Mounting Dimensions — Series 7886 High-Capacity Meter Register.

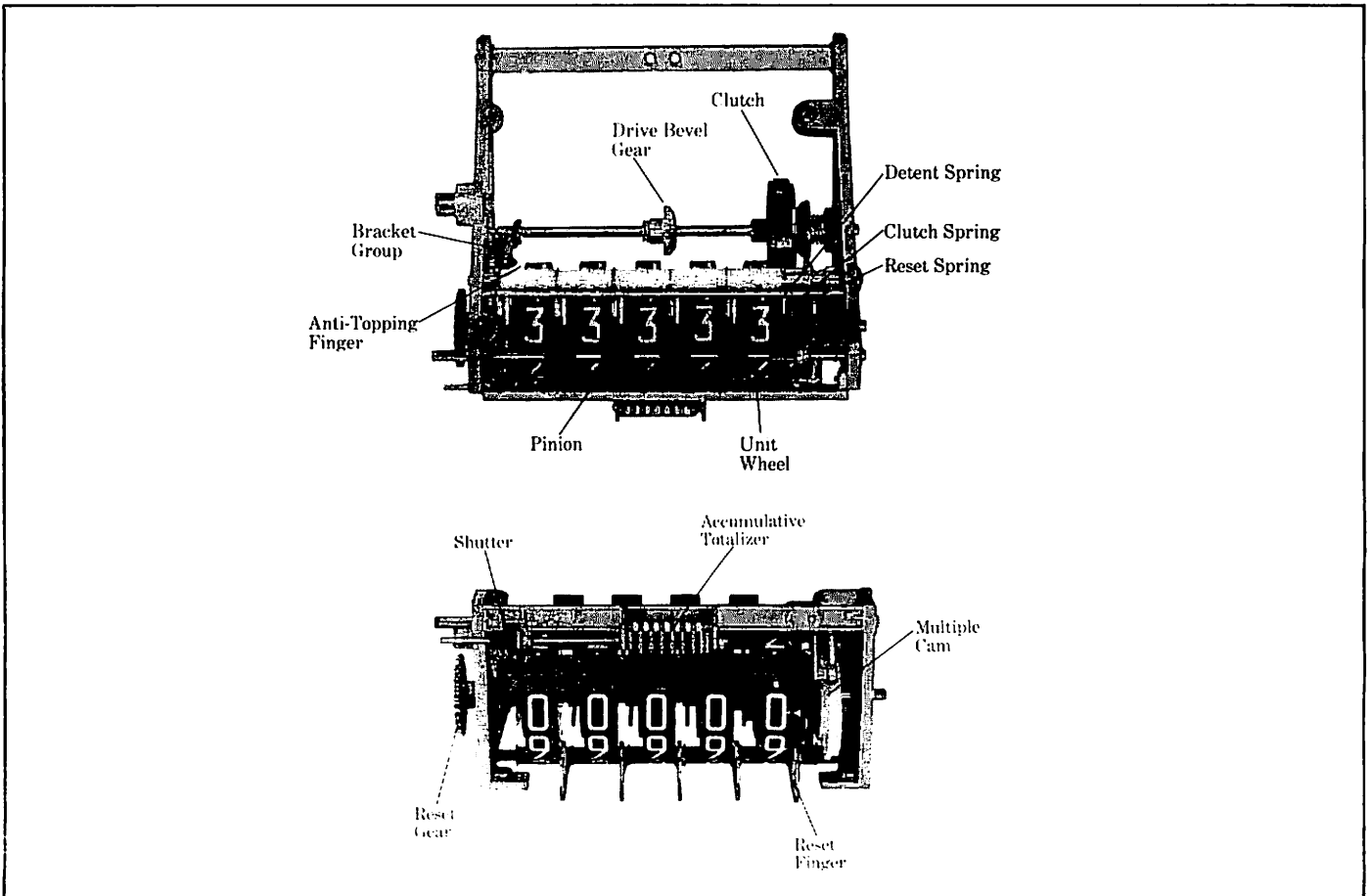

Figure 5. Internal View of Series 7887 Meter Register (Series 7886 High-Capacity Meter Register is similar).



SECTION 4. PERIODIC INSPECTION (For Series 7886 High-Capacity and Series 7887 Meter Registers)

A. GENERAL. The Meter Register is fully lubricated and properly adjusted at manufacture. However, periodic cleaning and lubrication are required.

Judgement of the intervals at which the meter register requires such service must necessarily be left to the individual user due to varying conditions of service. Under normal conditions, this will be at least once a year, or after each 2-1/2 million units of measure delivered, whichever comes first.

B. DISASSEMBLY PRIOR TO CLEANING. Remove the meter register from its housing as follows:

1. Remove the bolts securing the cover (if present) to the top of the housing. These bolts are hex head and are located at the four corners of the bottom of the housing. Remove the cover.
2. Remove the three button-head bolts securing the meter register to the housing. Remove the meter register.
3. Remove the screws securing the gear plate to the bottom of the housing. Remove the gear plate.

C. CLEANING.

CAUTION: DO NOT USE A WIRE BRUSH.

1. Wipe bezel crystal with a clean lint-free rag.
2. If the wheel faces are dirty, gently clean with a clean lint-free rag dipped in mild soapy water.
3. Clean the gears on the base plate by flushing or with a brush dipped in solvent. Blow dry with compressed air.
4. Clean housing by dipping, flushing or brushing with solvent. Blow dry with compressed air.

D. INSPECTION. A periodic inspection of the entire meter register, housing and gear plate is required to make sure that they function properly, parts are in place, and no binding or excessive side-to-side motion of shafts occurs. A checklist on such procedures follows:

1. Check the following shafts for perceptible side-to-side motion.

Note: Remove the meter register from the housing before checking shaft freedom.

- a. Wheel Shaft
 - b. Anti-Topping Finger Group Shaft
 - c. Reset Finger Group Shaft
 - d. Clutch Group Shaft
 - e. Pinion Shaft
2. Temporarily install the base plate and meter register in the housing and check for proper engagement and freedom of movement of:
 - a. All gears on gear plate.
 - b. Output bevel gear on gear plate with the bevel drive gear on drive shaft.

c. 57 tooth gear on clutch assembly with gear on right wheel assembly.

d. Gear drive shaft with gear train that operates the totalizer, and gear connecting the drive train to the totalizer.

3. Rotate drive shaft by hand to see that unit operates freely and then reset, checking for proper reset and shutter action. Adjust pointer after reset as required.

4. Check all screws, retaining rings and groove pins to see that they are tight and seated properly.

E. LUBRICATION.

1. Recommended Lubricants

Note: Chemlube and Vischem products are manufactured by Ultrachem Inc.,
 1400 N. Walnut St., P.O. Box 2053
 Wilmington, DE 19899

Oil: Chemlube 201 or equivalent with a temperature range of -65°F to +275°F (-54°C to +135°C).

Grease: Vischem 352 or equivalent with a temperature range of -65°F to +300°F (-54°C to +149°C).

Note: All lubricants used in the register must be of a type which remains fluid over the full temperature range to which the register will be subjected. Also, they should not oxidize or dry out leaving a gummy or perceptible residue.

If the Chemlube 201 oil lubricant is not available, a substitute with equivalent properties may be used. To assist field personnel in obtaining suitable lubricants for the meter register and ticket printers, the following list showing equivalent lubricants has been prepared:

OIL

AEROSHELL FLUID	NO. 3
REGENT SPINTEX OIL	60
GARGOYLE ARCTIC OIL	LIGHT
CASTROL HYSPIN	40
ANDEROL	401D

GREASE

AEROSHELL	14
ESSO BEACON	325
ANDEROL	795

2. Points to Lubricate

Oil: All points indicated as "Oil" on Figure 6 should be lubricated with oil as described above. This includes all shafts, studs, and bosses on which a moving part bears.

Grease: Grease should be applied to all points indicated as "Grease" on Figure 6. This includes gears and the no-back ratchet and pinion.

Note: The oil and grease should be applied with a small brush to make certain that all areas will be properly lubricated. In this manner, the amount of lubricant being used will be more easily controlled.

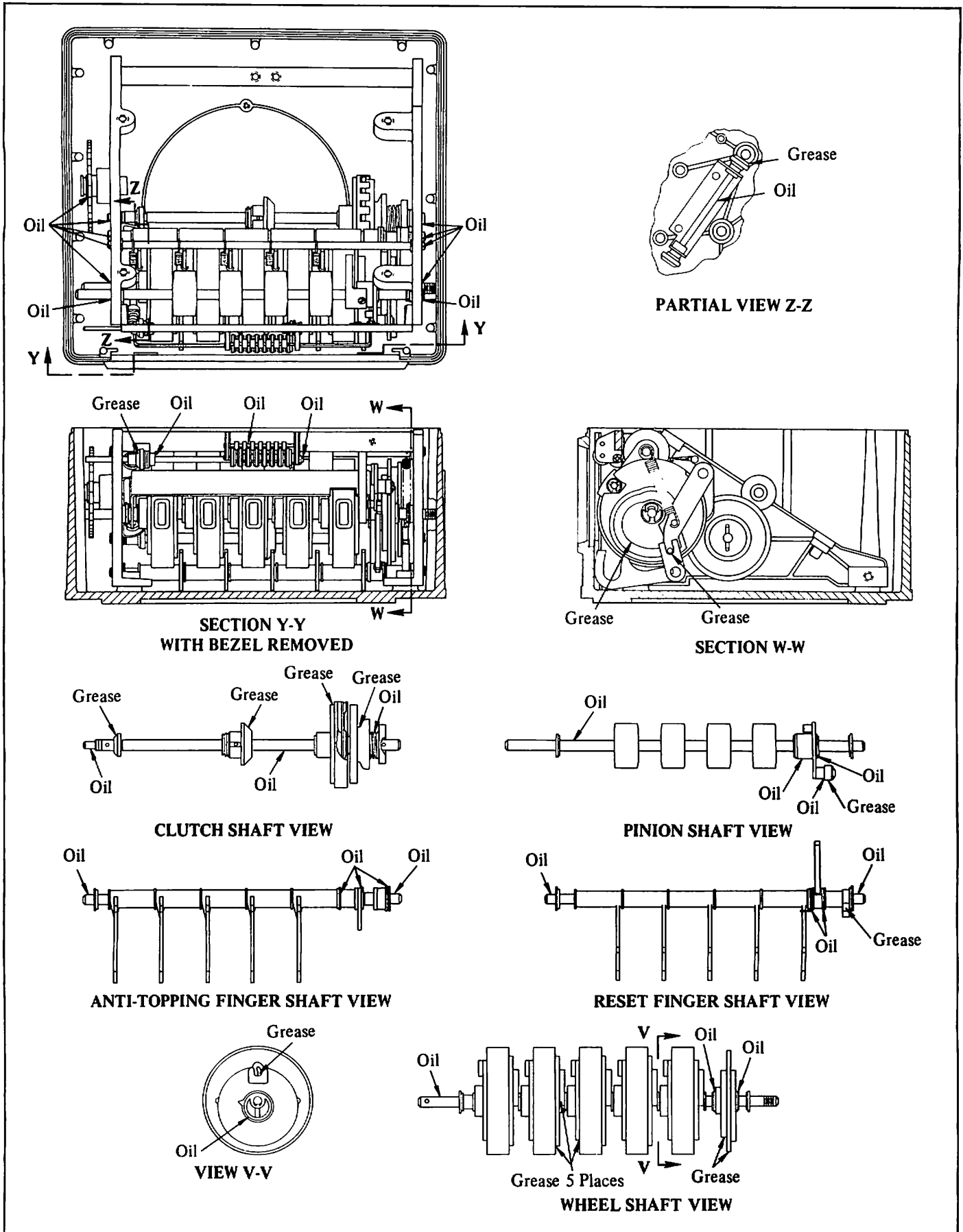

Figure 6. Lubrication Points.



F. TROUBLESHOOTING. Table 1 is used to assist in locating problems and making repairs and corrections. In some problems, similar defects can be produced by several causes of an entirely different nature. Cause of the trouble must be determined and the correction made.

Table 1. Troubleshooting

TROUBLE	POSSIBLE CAUSE	CORRECTION
1. Drive shaft hard to turn.	Pointer or brake rubbing on first wheel. Dirt or pieces of foreign material in teeth of drive shaft gears, gear plate, totalizer or bevel gear train driving totalizer.	Check pointer and brake positioning. Adjust as required. Remove case. Check all gears, clean and lubricate as necessary. See Section 4.
2. Binding occurs during reset cycle.	Missing washers on outside of clutch shaft. Pinion jam, anti-topping finger(s) broken or spring(s) missing.	Check end play and washer as required. Check end play of wheel shaft. Replace broken anti-topping fingers or missing springs.
3. Reset knob turns hard.	Reset knob flange on the case binds on reset shaft. Wheel shaft group is bent. Reset fingers rubbing on wheel or retaining rings.	Remove reset knob. Loosen flange screws, center the flange on the shaft and tighten the screws. Replace wheel shaft. Check for missing retaining rings on reset finger and wheel shafts. Replace as required.
4. Any one wheel will not reset to zero.	Broken reset finger. Locking disc pin out of wheel groove.	Replace reset fingers as required. Disassemble wheel group and insert locking disc pin into groove in wheel.
5. Incomplete reset cycle. Knob turns but reset does not occur,	Key in large multiple cam broken. Reset actuating lever not engaged in cam or reset arm broken.	Replace cam with new cam and key. Remove cam, inspect and replace parts as required, and assemble properly.
6. Shutter partially obscured wheels at completion of reset cycle or completely covers wheels at end of reset cycle.	Shutter disconnected from reset lever.	Connect shutter to reset lever.
7. Shutter will not drop into place or loss of detent action during reset.	Detent lever spring missing or broken.	Install new spring.
8. Pointer not aligned with unit wheel.	Improper adjustment of brake or pointer.	Adjust brake to proper clearance. Adjust pointer to center mark.
9. Unit wheel can be turned in reverse by hand.	Dirty drive shaft clutch assembly.	Clean clutch group and lubricate. See Section 4.
10. Cannot drive meter register.	Pinion jam, reset fingers are engaged, heart cams hit on detent lever shutter stud, clutch not engaged.	Check washers on pinion shaft. Check end play of shafts. Clean and lubricate clutch.

SECTION 5. DISASSEMBLY AND ASSEMBLY
(For Series 7886 High-Capacity
and Series 7887 Meter Registers)

A. GENERAL. When disassembling the meter register, be extremely careful not to lose or intermix any of the washers found on the shafts. By doing so, potential problems with end-play and backlash adjustments will be greatly lessened. When removing retaining rings or other parts from shafts, do not hold the shaft with any tool that might gouge or create burrs on the shaft.

B. REMOVAL OF MAJOR GROUPS. Instructions for removal of all shaft groups are provided.

1. If present, remove the retaining ring securing the reset idler gear to the reset idler gear shaft.
2. Remove retaining rings and washers securing the pinion, reset, anti-topping and clutch shafts to the right-hand side plate (Figure 7). Remove screws and lockwasher securing the totalizer group and rear mounting bar from right-hand side plate.
3. Remove side plate.

CAUTION: DO NOT LOSE OR INTERMIX WASHERS FROM EACH SHAFT.

Note: Remove only those shaft groups necessary to gain access to parts being replaced.

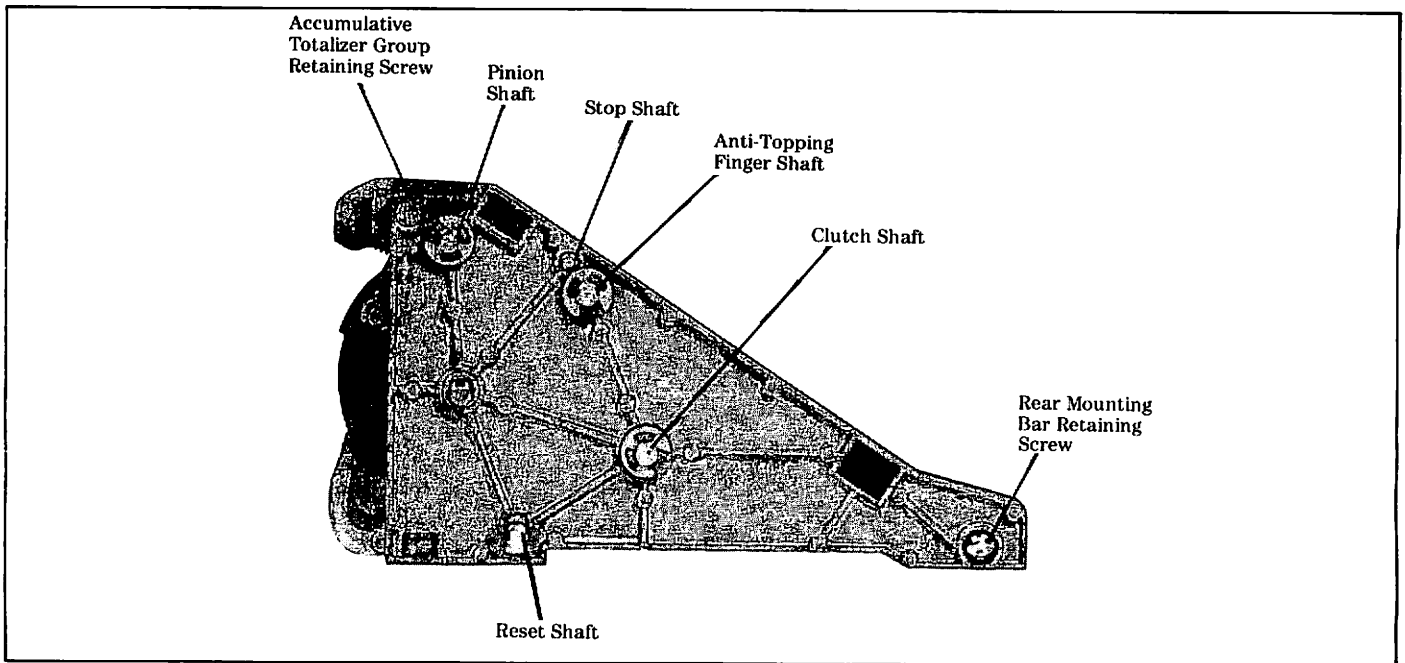

Figure 7. Right-Hand Side Plate.

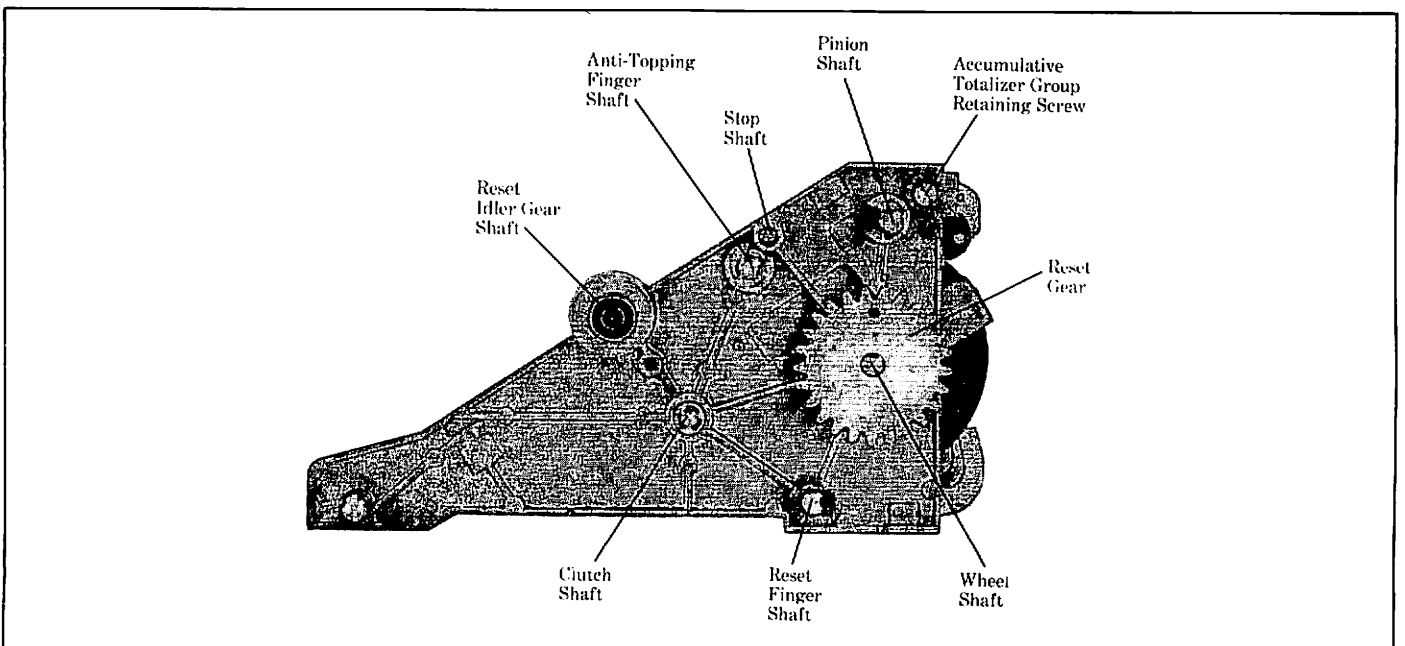

Figure 8. Left-Hand Side Plate.

4. Clutch Shaft Group Removal.
 - a. Remove retaining ring and washers securing the clutch shaft group to the left-hand side plate. See Figure 8.
 - b. Move clutch lever group so clutch is free. See Figure 9. Remove clutch shaft group. See Paragraph C, 1 for parts replacement.
5. Reset Finger Group Removal.
 - a. Remove retaining ring and washer securing the reset group to the left-hand side plate. See Figure 8.
 - b. Disengage the reset fingers and no-back pawl from the wheels. See Figure 10. Remove the group. See Paragraph C, 2 for parts replacement.
6. Stop Shaft Removal.
 - a. Remove the springs from between the anti-topping fingers and the stop shaft.
 - b. Remove the spring from between the detent lever group and the stop shaft.
 - c. Remove the stop shaft.
7. Anti-Topping Finger Group Removal.
 - a. Remove the retaining ring and washers securing the anti-topping finger group shaft to the left-hand side plate. See Figure 8.
 - b. Disengage the anti-topping fingers and the clutch lever group from the wheels. See Figure 11.
 - c. Remove the group from the side plate. See Paragraph C, 3 for parts replacement.
8. Totalizer Group Removal.
 - a. Remove the screws securing the totalizer group to the left-hand and right-hand side plates. See Figures 7 and 8.
 - b. Remove the totalizer group.
 - c. No additional disassembly of the totalizer is possible. If the totalizer is inoperable, replace the group.

- Note:** If the inoperable totalizer has a small bevel gear (approx. 11/32 inch dia.) on the drive shaft, replace the bracket group on the left side frame as well as the totalizer group (see Figure 31 and Paragraph D, 7 and E, 5). Remove the screw holding the pointer onto the old totalizer and save for installation on new totalizer.
9. Pinion Removal.
 - a. Remove retaining ring securing pinion shaft to the left-hand side plate. See Figure 8.
 - b. Rotate the detent lever group so it will clear the reset cam. Remove shaft.
 - c. Remove pinions, detent lever group washers and retaining rings from shaft.
 10. Wheel Group Removal.
 - a. Mark relationship of reset gear to wheel group shaft to assure proper positioning during assembly.
 - b. Remove pin securing reset gear to the wheel group shaft.
 - c. Remove gear, retaining ring and washer. Remove shaft. See Paragraph C, 4 for parts replacement.

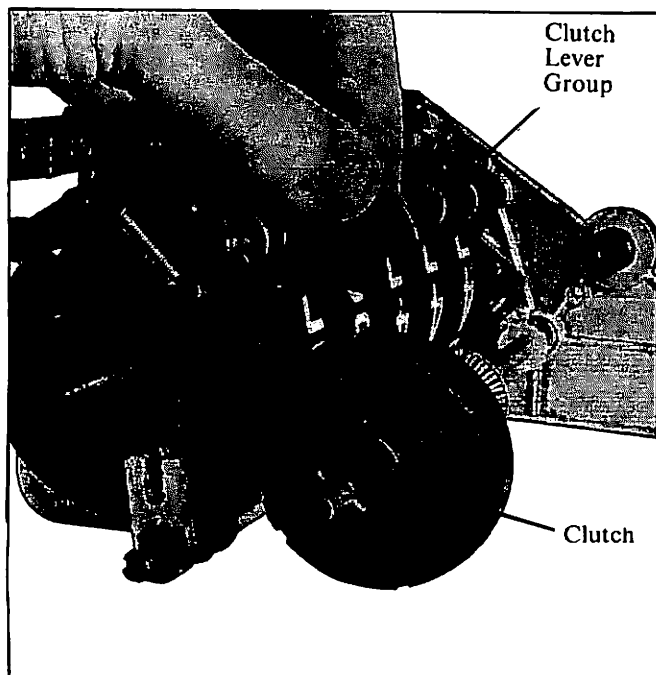

Figure 9. Clutch Group Removal

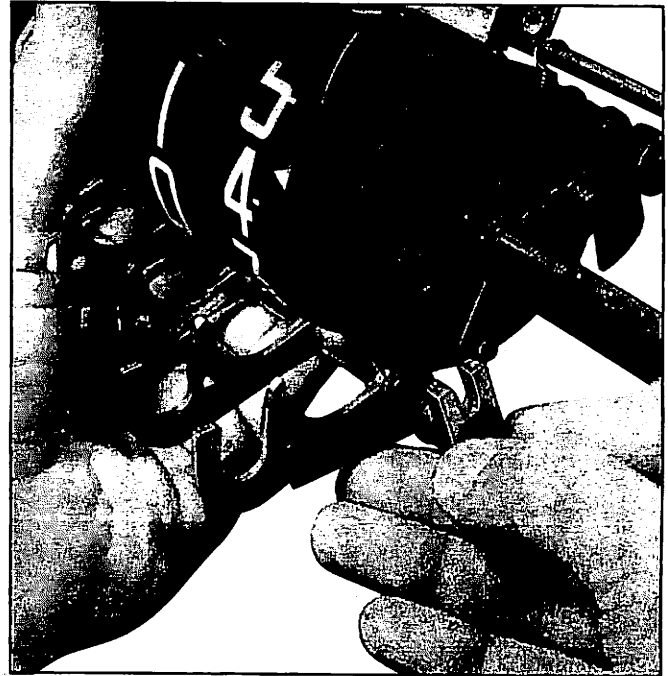

Figure 10. Reset Finger Group Removal.

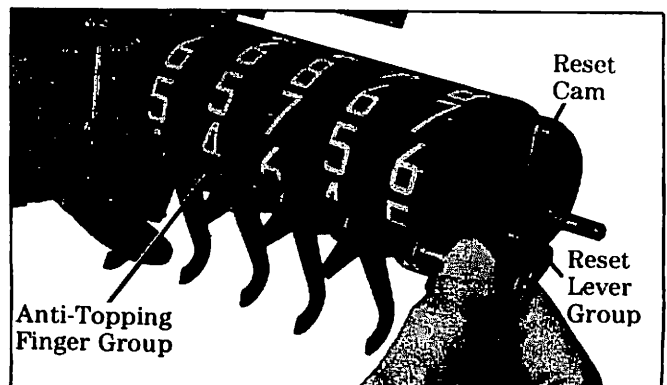

Figure 11. Anti-Topping Finger Group Removal.

C. INDIVIDUAL PARTS REPLACEMENT

1. Clutch Shaft Parts Replacement. See Figure 12.

- a. Totalizer and Drive Bevel Gears.
 - (1) Drift out pin securing gear to shaft.
 - (2) Remove gear.
 - (3) Remove retaining rings and washers that position drive gear. Do not change the order of the rings and washers.
 - (4) Drift out pin holding drive gear and remove gear.
 - (5) Install new gear, pin, retaining rings and washers. Use new pin if required.
 - (6) Install totalizer bevel gear and secure with pin.

CAUTION: CHECK SHAFT FOR STRAIGHTNESS AFTER PINNING. A BENT SHAFT WILL CAUSE BINDING DURING DRIVING OF METER REGISTER. CLUTCH MUST NOT BE DISASSEMBLED OR REPLACED AS AN INDIVIDUAL GROUP. IF CLUTCH IS BROKEN OR MALFUNCTIONS, REPLACE COMPLETE SHAFT AND CLUTCH AS AN ASSEMBLY.

2. Reset Finger Group Parts Replacement. See Figure 13. Individual reset fingers, reset arm, no-back pawl and pawl spring may be replaced as required.

- a. Remove retaining rings and appropriate washer to reach particular part.
- b. Replace defective items with new part. Assemble remaining parts on shaft. Install retaining rings and washers. Check end play per Figure 28.

3. Anti-Topping Finger Group Parts Replacement. See Figure 14. Individual anti-topping fingers, reset lever and clutch lever may be replaced as required.

- a. Remove retaining rings, washers and parts as required to get to part that is to be replaced.
- b. Install parts, retaining rings and washers in the sequence shown in Figure 14. Be sure to install parts so they are in the proper direction. Check end play per Figure 28.

4. Wheel Group Parts Replacement. See Figures 15, 16, 17 and 18. The reset cam, individual wheels, locking discs and eccentrics may be replaced as required.

- a. Remove retaining rings, washers and key as required to remove reset cam, wheels, locking discs and eccentrics.
- b. Install parts, retaining rings, washers and key in the sequence shown in Figure 17. When installing wheels, be sure the pin on the locking disc engages the groove in the wheel as shown in Figure 18. Check end play per Figure 28.

D. INSTALLATION OF MAJOR GROUPS

Prior to installing each shaft, lubricate per Paragraph E in Section 4. During assembly, do not intermix washers from one shaft to another.

1. Wheel Group Installation.

- a. If not present, install a 0.030 inch thick washer over the end of the wheel group shaft opposite the cam.
- b. Install the shaft into the proper hole in the left-hand side plate. See Figure 8.

2. Anti-Topping Finger Group Installation. See Figure 19.

- a. Hold wheel and side plate assembly upside down.
- b. Install anti-topping finger group in proper hole in left-hand side plate (see Figure 8). Be sure all fingers and clutch lever are free of wheels and the pin on the reset lever engages the track on the cam.

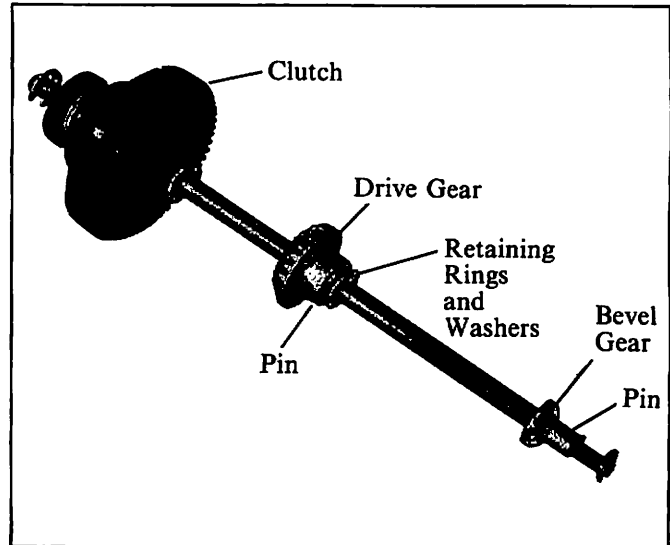

Figure 12. Clutch Shaft Group.

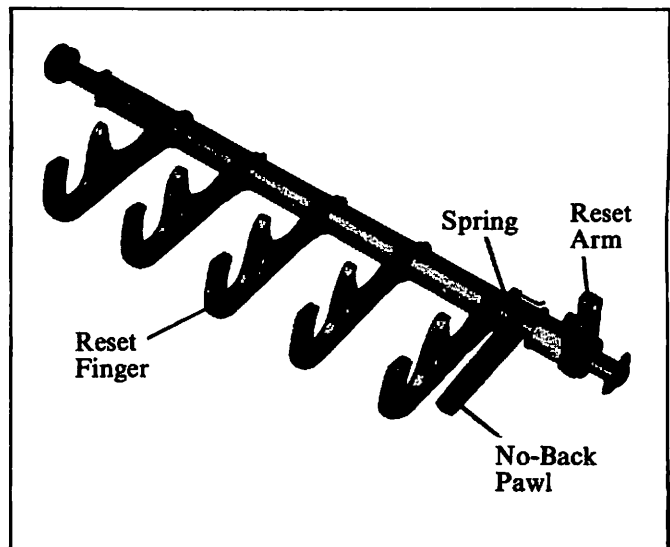

Figure 13. Reset Finger Group.

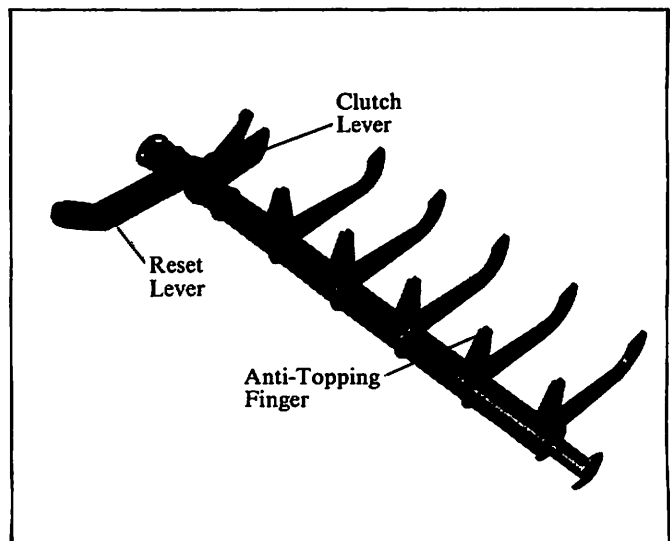

Figure 14. Anti-Topping Finger Group.

- c. Seat the shaft, install washers and retaining ring to secure shaft to left-hand side plate.
 - d. See that all fingers are free to engage wheels.
3. Stop Shaft Installation.
- a. Install retaining rings on ends of shaft.
 - b. Insert stop shaft into proper hole in left-hand side plate. See Figure 8.
4. Reset Finger Shaft Group Installation.
- a. Rotate no-back pawl so that spring puts pawl under tension. Slip an elastic band over the reset fingers and pawl to hold pawl in position. See Figure 20.
 - b. Install shaft into left-hand side plate and secure with retaining ring and washers. See Figure 8.
 - c. Engage pin on reset lever group with slot in reset arm. See Figure 22.
5. Clutch Shaft Group Installation.
- a. Install shaft in proper hole in left-hand side plate. Add washers and secure with retaining ring. See Figure 8.
 - b. Make sure that bevel gears that drive the totalizer are free to turn.

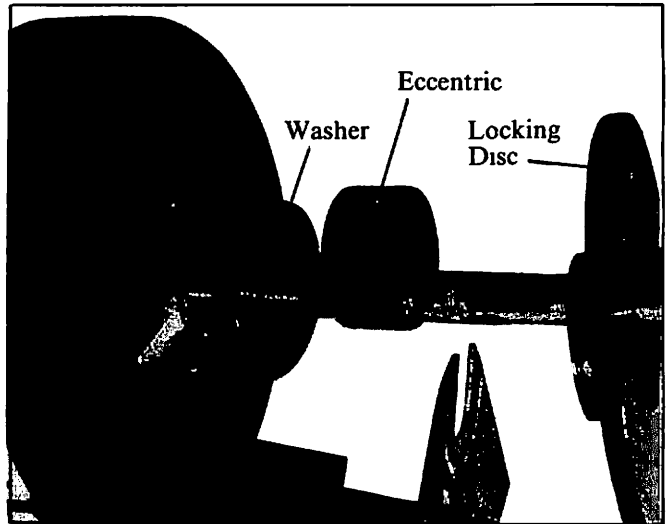

Figure 17. Locking Disc, Eccentric and Washer Removal and Installation.

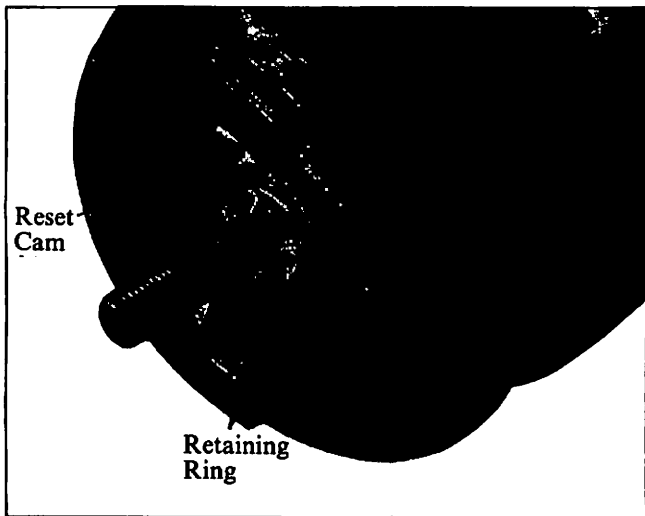

Figure 15. Reset Cam Removal.

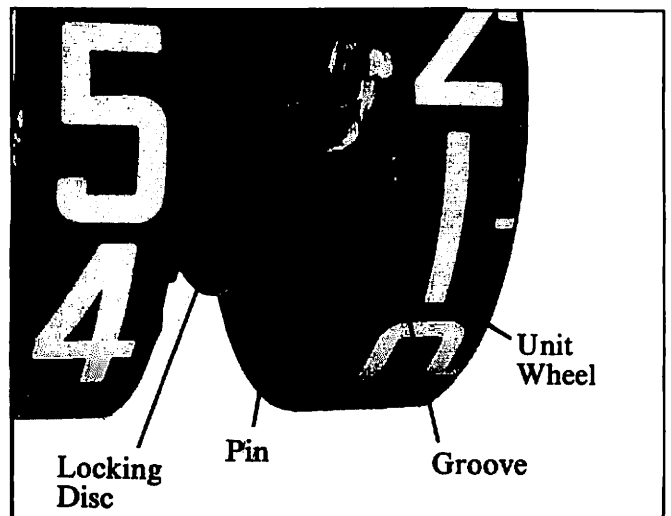

Figure 18. Unit Wheel Installation.

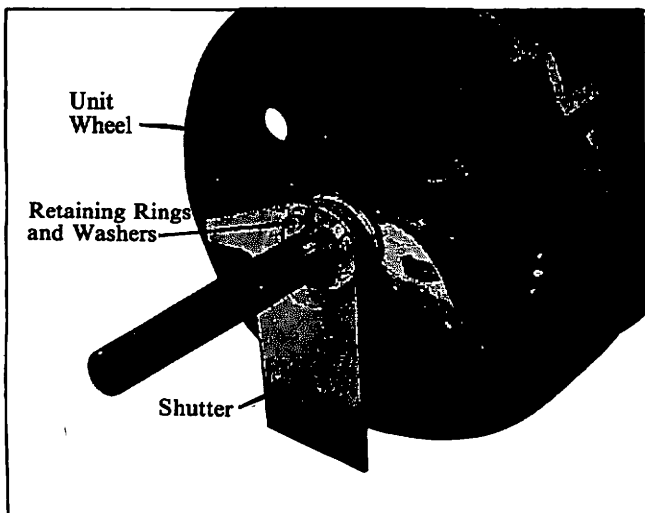

Figure 16. Unit Wheel Removal.

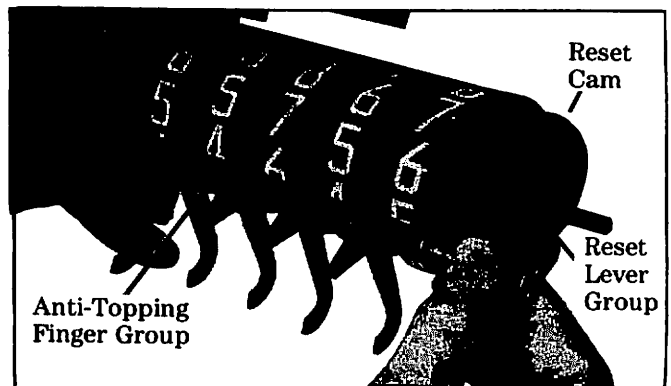

Figure 19. Anti-Topping Finger Group Installation.

6. Right-Hand Side Plate Installation

- a. Hold meter register assembly as shown in Figure 22 and place a rubber band around the assembly to hold it together. Be sure the pin in the reset lever group remains engaged in the slot in the reset arm.
- b. Install side plate over wheel shaft first, then engage the other shafts.
- c. Temporarily secure the side plate to the rear mounting bar with screws.

7. Bracket Group (if required) and Totalizer Installation.

- a. If required, install new bracket group to inside of left side frame and secure with two screws and lock-washers. See Figure 31.
- b. Install pointer with screw (saved from old totalizer) onto new totalizer group but do not tighten screw securely. Pointer position must be adjusted after totalizer group is installed. See Paragraph F, 2.
- c. Install the totalizer group so that the bevel gear is in mesh with the top bevel gear on the bracket group and secure with retaining screws. For adjustment of bevel gear drive, see Paragraph E, 5.

8. Spring Installation.

- a. See Figure 23 for identification of springs.
- b. Install the five anti-topping finger springs between the anti-topping fingers and the stop shaft. See Figure 24.
- c. Install the reset spring between the reset lever and the pinion shaft.
- d. Install the detent spring between the detent lever group and the stop shaft.
- e. Install the clutch spring between the clutch lever group and the pinion shaft.

9. Pinion Shaft Assembly Installation

- a. If not previously accomplished, remove all parts from pinion shaft.
- b. Rotate wheel shaft so reset fingers are fully engaged in the heart-shaped cams on each wheel.
- c. Place pinions, with short finger up, in between each wheel as shown in Figure 25.
- d. Install the end of the shaft closest to the two retaining ring slots into the left-hand side plate and through each pinion.

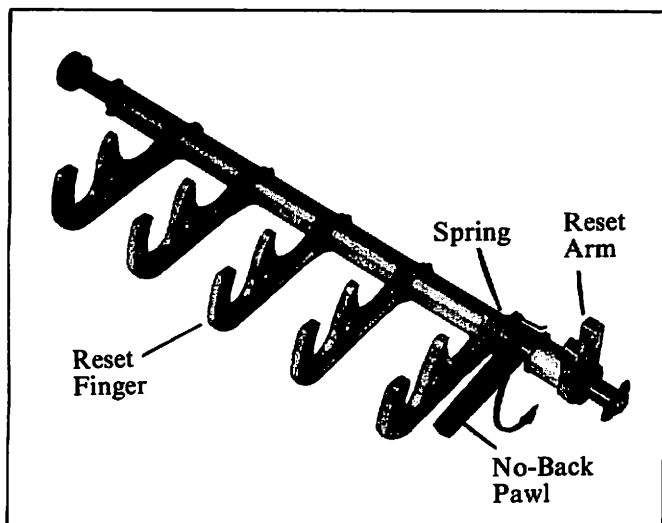

Figure 20. Reset Finger Shaft Group Preparation For Installation.

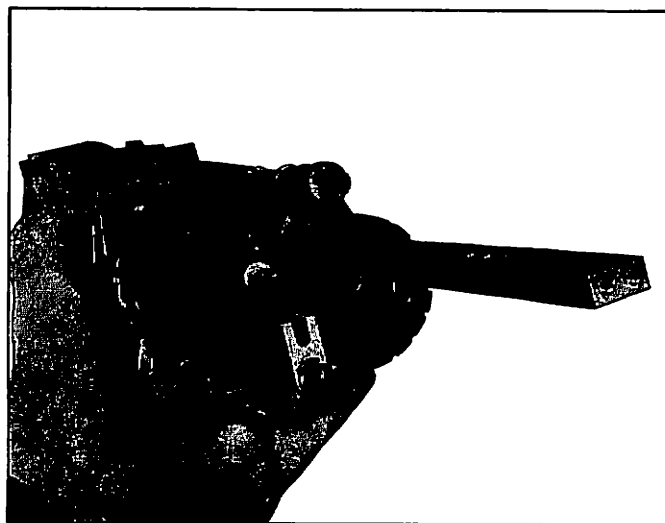

Figure 22. Preparation For Side Plate Installation.

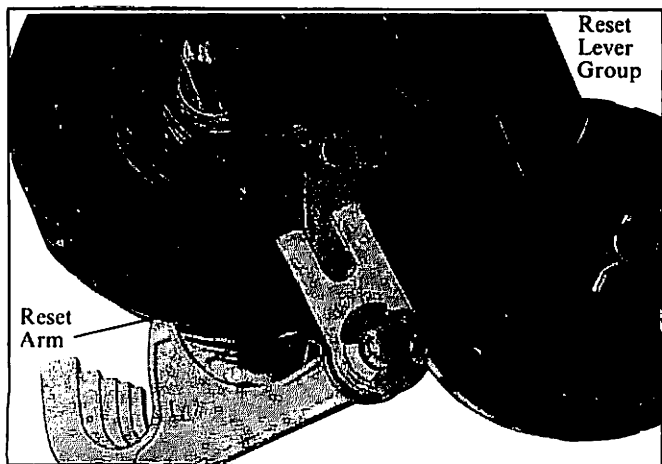

Figure 21. Reset Lever Group Pin Engagement.

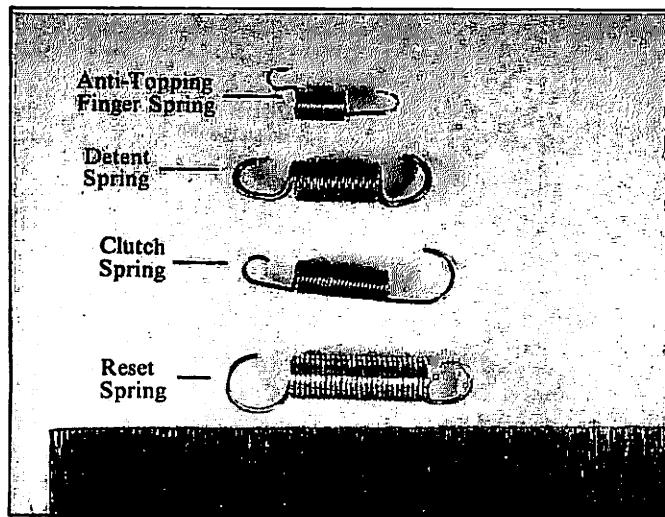

Figure 23. Spring Identification.

- e. Install washers and detent lever group onto shaft and engage shutter with tab on detent lever.
- f. Push shaft through the right-hand side plate and secure with washer and retaining ring.
- g. Secure detent lever group into position with retaining rings.
- h. After assembly, rotate wheel shaft to make sure all pinions have been positioned properly. If binding occurs, reposition pinions per step c.

10. Reset Gear Installation.

- a. Install reset gear on wheel shaft, aligning orientation mark made at disassembly.
- b. Secure gear to shaft with pin.

11. Reset Idler Gear Installation.

- a. If present, install reset idler gear on the reset idler gear shaft. See Figure 8.
- b. Secure with retaining ring.

Note: This gear will be timed when the meter duplicator and meter register are assembled together.

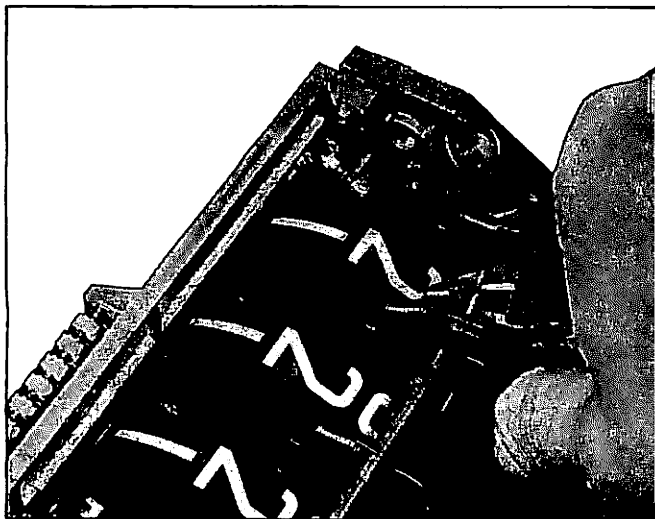

Figure 24. Anti-Topping Finger Spring Installation.

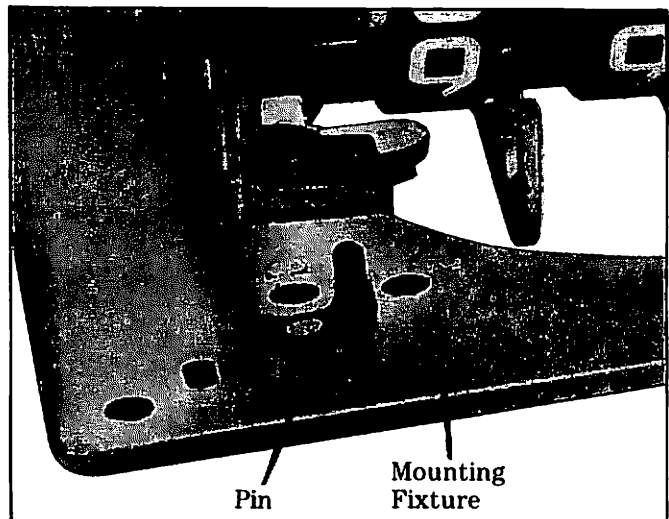

Figure 26. Installation Of Meter Register Onto Mounting Fixture.

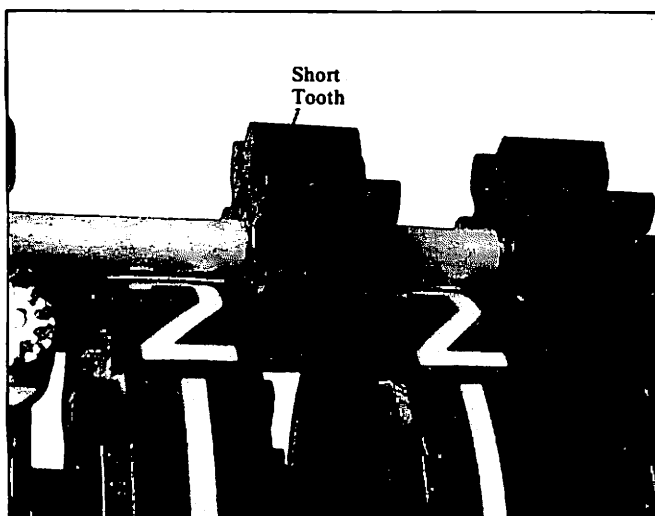

Figure 25. Pinion Positioning.

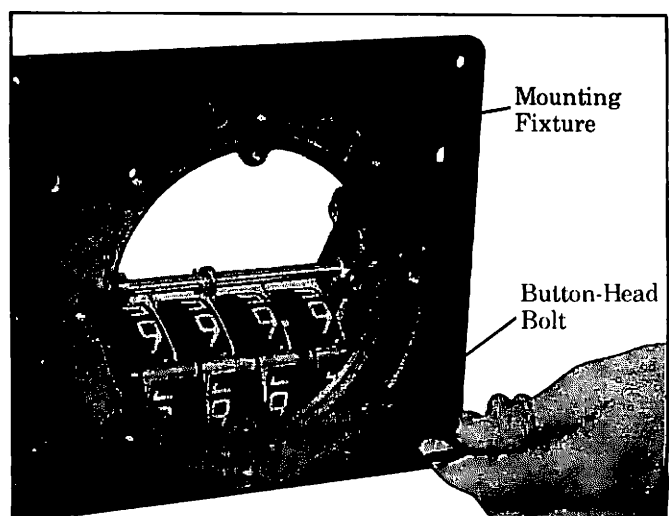

Figure 27. Securing Mounting Fixture.

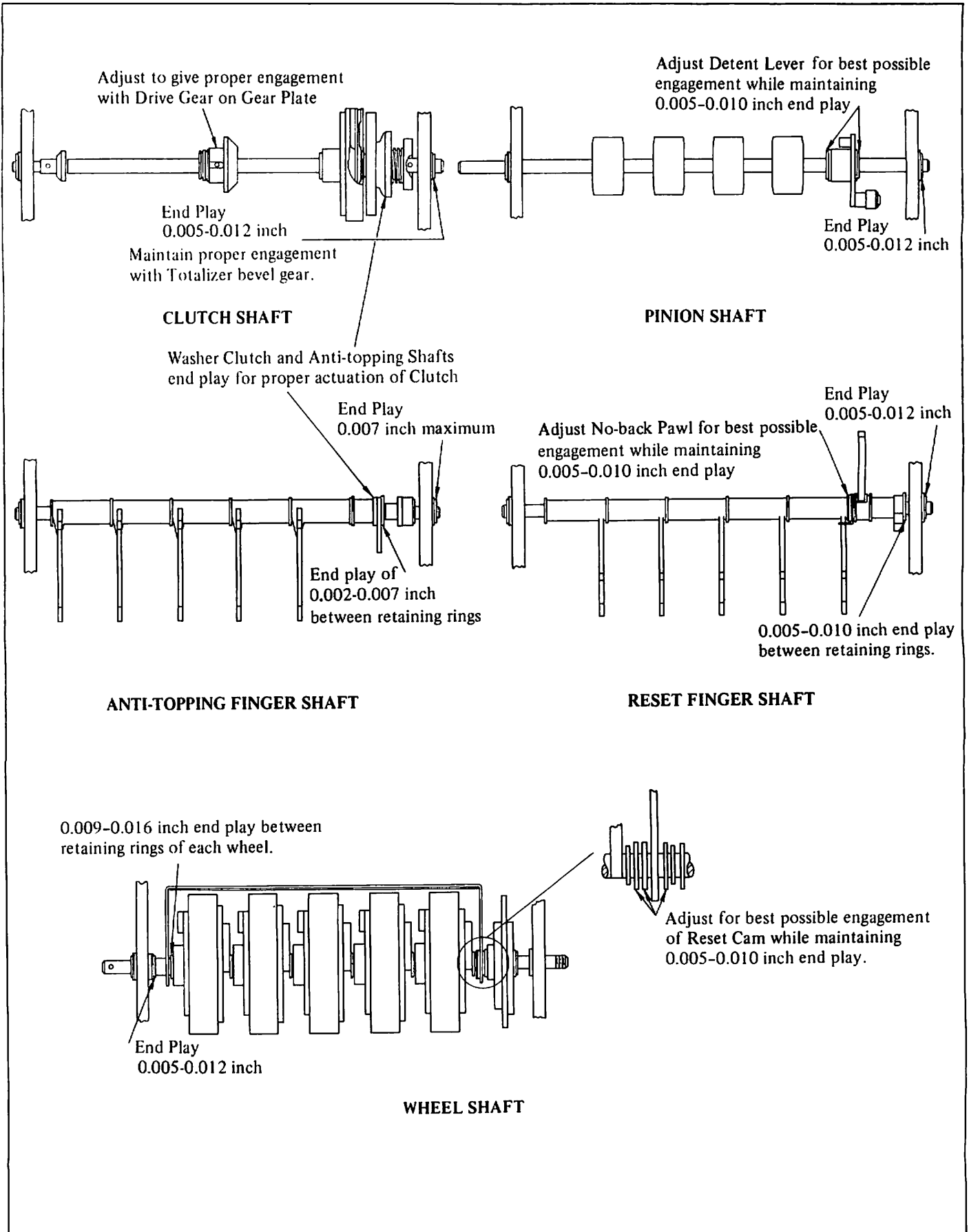

Figure 28. End Play Limits.

E. FINAL CHECKS AND ADJUSTMENTS.

1. End Play Check: Check end play (back and forth motion) of shafts and parts as follows:
 - a. For proper measurement, the meter register must be installed in the TD-42383 mounting fixture, Figure 26, to constrain the frame into the same position that it is when installed in the housing.
 - b. Secure the meter register to the fixture with two 1/4-28 button-head bolts. See Figure 27.
 - c. Take end play measurements of each shaft. Add or subtract washers as necessary to obtain correct end play.
2. Input Drive Bevel Gear Engagement Adjustment.
 - a. Install the gear plate onto the fixture using the appropriate hardware.
 - b. Remove the retaining ring behind the bevel gear and add or subtract washers as required for proper mesh between the bevel gear on the gear plate and the drive bevel gear on the clutch shaft. The shaft end play must be maintained as specified in Figure 28.
 - c. Replace the retaining ring after adjustment.
3. Clutch Lever Positioning Adjustment.
 - a. Rotate the reset gear until the clutch is fully disengaged.
 - b. Measure the clearances as shown in Figure 29.
 - c. If the dimensions cannot be obtained, add or remove washers as required, or replace the clutch and shaft.
 - d. The amount of face engagement between the spur gear on the input clutch and the first wheel should be $75\% \pm 20\%$.
4. Wheel Brake Adjustment.
 - a. Rotate reset gear to position cam as shown in Figure 30.
 - b. Measure clearance between brake and first wheel. If clearance is not within the dimensions given, adjust brake by loosening screw and moving brake into position.
 - c. Remove the meter register from the fixture by removing the two button-head screws. Remove the gear plate from the fixture.
5. Gearing Adjustment for Totalizer. See Figure 31.

Loosen set screw on bottom bevel gear. Mesh the top bevel gear tightly with the totalizer bevel gear. Press the register clutch shaft toward the left side frame. Adjust the bottom bevel gear such that it has 0.012 - 0.015 end play when meshing with the clutch shaft bevel gear. Tighten set screw and secure with a sealant (Loctite 222 or equivalent) to prevent loosening.
6. Apply Anderol L-795 or equivalent grease on teeth of bevel gears.

7. Backlash Compensating Mechanism Adjustment for EEC UNITS ONLY.

While unit is running at 100-200 RPM, adjust screw so that pawl is approximately in the middle of clip as shown in Figure 32 (on Page 16). Oscillation of pawl is permissible.

To check for proper operation, use a 1:1 gear plate and operate register at 100-200 RPM. Stop counting, hold input shaft of gear plate and reset register. Wheel should reset so that some part of graduation at zero always aligns with pointer.

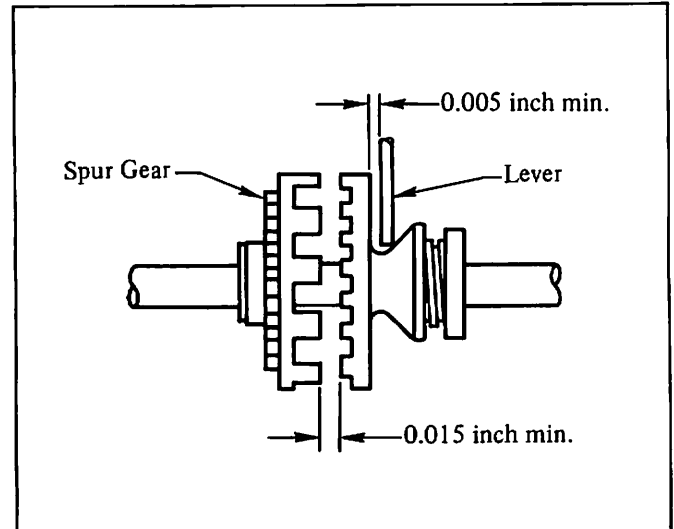

Figure 29. Clutch Lever Adjustment.

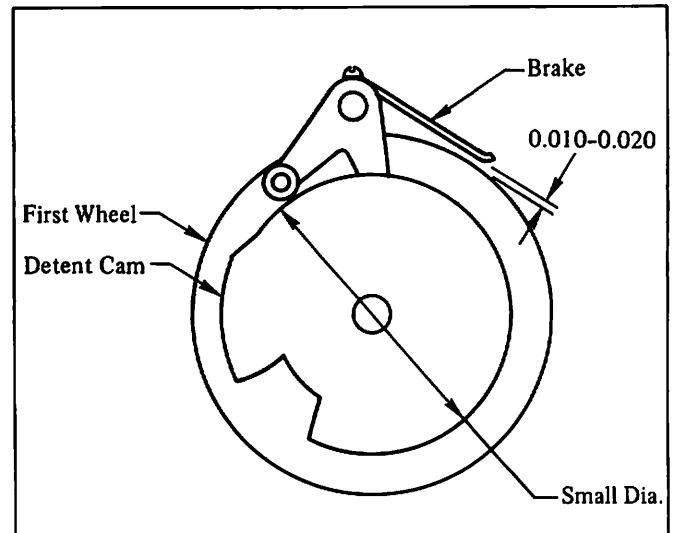

Figure 30. Brake Adjustment.

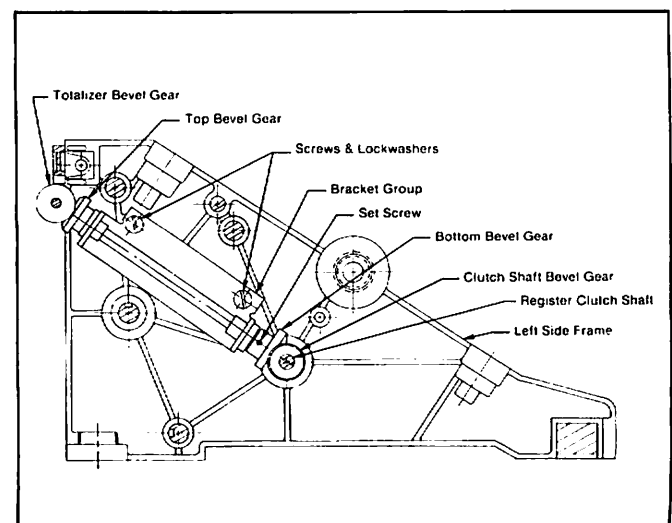

Figure 31. Inside Left Side Plate of Meter Register.

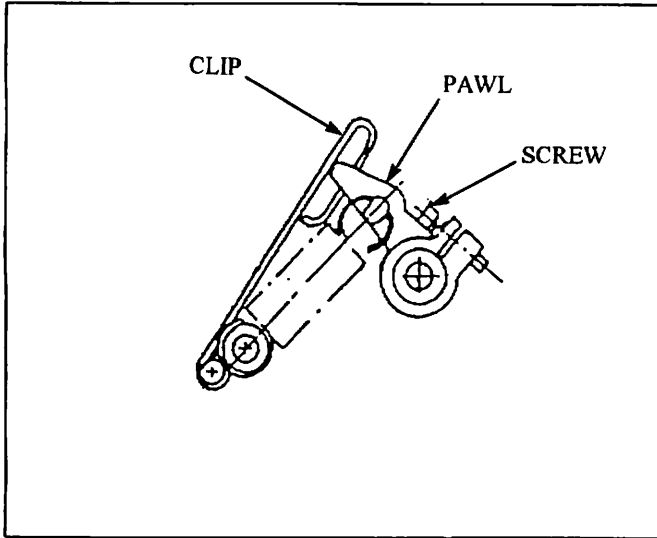

Figure 32. Backlash Compensating Mechanism (EEC UNITS)

F. OPERATIONAL CHECK. Before returning the meter register to normal service, check that it operates properly as follows:

1. Rotate the input bevel gear and see that the totalizer and individual delivery wheels are driven and that they record the same amount. There should be no binding or drag.
2. Rotate the reset gear and see that the shutter drops into place, the wheels all reset and that there is no binding or drag. At the completion of reset, the zeros should align with the pointer.
3. See Troubleshooting, Table 1, Page 5, if there are any problems.

SECTION 6. DAMAGE CLAIMS AND WARRANTY

A. DAMAGE CLAIMS

1. Thoroughly examine the enclosure as soon as it is received. If damaged, write on the face of the freight bill a complete and detailed description of the damage. Have the carrier's agent sign the description.

Note: Insist that the carrier's agent verify the inspection and sign the description.

2. Immediately notify the delivering carrier of damage or loss. This notification may be given either in person or by telephone. Written confirmation must be mailed within 48 hours. Railroads and motor carriers are understandably reluctant to make adjustments for damaged merchandise unless inspected and reported promptly.
3. Risk of loss of, or damage to merchandise remains with the Buyer. It is the Buyer's responsibility to file a claim with the carrier involved.
4. Immediately advise your Veeder-Root representative, distributor, or the factory so that we may assist you.

B. RETURN SHIPPING. All shipments of Veeder-Root products must be prepaid. Equipment must be packed in a strong exterior container and surrounded by shock absorbing material. Veeder-Root will accept no liability for damage caused by improper packing. It is suggested that the original shipping container be used if it is available. Address shipment to Veeder-Root Co., 6th Avenue at Burns Crossing, P.O. Box 1673, Altoona, PA 16603.

C. WARRANTY AND CONDITIONS

1. WARRANTY. We warrant that our products shall be free from defects in material and workmanship for a period of one year from the date of shipment thereof or the product's total rated life, whichever first occurs. Within the warranty period we shall repair or replace such products which are returned to us with shipping charges prepaid and which are determined by us to be defective. This warranty will not apply to any product which has been subjected to misuse, negligence, or accident; or misapplied; or used in violation of product manuals, instructions, or warnings; or modified or repaired by unauthorized persons; or improperly installed.

2. INSPECTION. You shall inspect the product promptly after receipt and shall notify us at our Altoona office, in writing, of any claims, including claims of breach of warranty, within thirty days after you discover or should have discovered the facts upon which the claim is based. Your failure to give written notice of a claim within the time period shall be deemed to be a waiver of such claim.

3. LIMITATION OF REMEDY AND WARRANTY. The provisions of Paragraph 1 are our sole obligation and exclude all other remedies or warranties, express or implied, including warranties of MERCHANTABILITY and FITNESS FOR A PARTICULAR PURPOSE, whether or not purposes or specifications are described herein. We further disclaim any responsibility whatsoever to you or to any other person for injury to person or damage to or loss of property or value caused by any product which has been subjected to misuse, negligence, or accident; or misapplied; or used in violation of product manuals, instructions, or warnings; or modified or repaired by unauthorized persons; or improperly installed.

4. LIMITATION OF DAMAGES. Under no circumstances shall we be liable for any incidental, consequential or special damages, losses or expenses arising from this contract or its performance or in connection with the use of, or inability to use, our product for any purpose whatsoever.

5. LIMITATION OF ACTIONS. No action regardless of form arising out of this contract may be commenced more than one year after the cause of action has accrued, except an action for nonpayment.

6. COLLATERAL PROMISES. There are no representations, warranties, or conditions express or implied, statutory or otherwise except those herein contained, and no agreements or waivers collateral hereto shall be binding on either party unless in writing and signed by you and accepted by us at our Altoona office.

7. INTERPRETATION. Rights and liabilities arising out of any contract with us shall be determined under the Uniform Commercial Code as enacted in Connecticut.

Accu-Flo

Meter Service Ltd.

4028 - 7th Street S.E., Calgary Alberta T2G 2Y8
Phone: (403) 243-1425 Fax: (403) 243-6577
Toll Free: 1-800-921-ACCU(2228), sales@accuflo.com



6th Avenue at Burns Crossing, P.O. Box 1673, Altoona, PA 16603-1673 Phone (800) 873-3313, Fax (800) 234-5350, or Phone (814) 695-4476, Fax (814) 695-7605

BRAZIL: Sau Paulo • CANADA: Mississauga, Ontario • ENGLAND: Richmond Surrey • FRANCE: Rungis Cedex • GERMANY: Neuhausen/Filder • SINGAPORE: Singapore
251325 (REV. B) 13355 Replaces 12569

VC12 PRINTED IN U.S.A. 95